

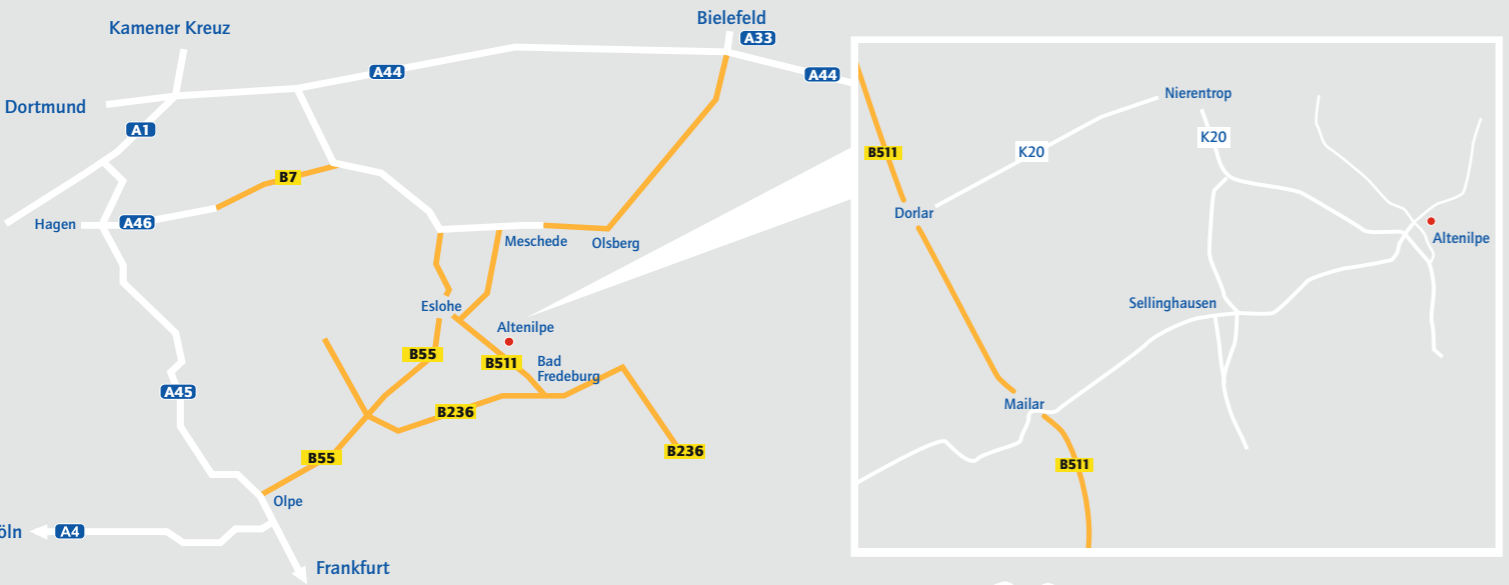

Scraper chain

Duplex chain

Becherwerkskette

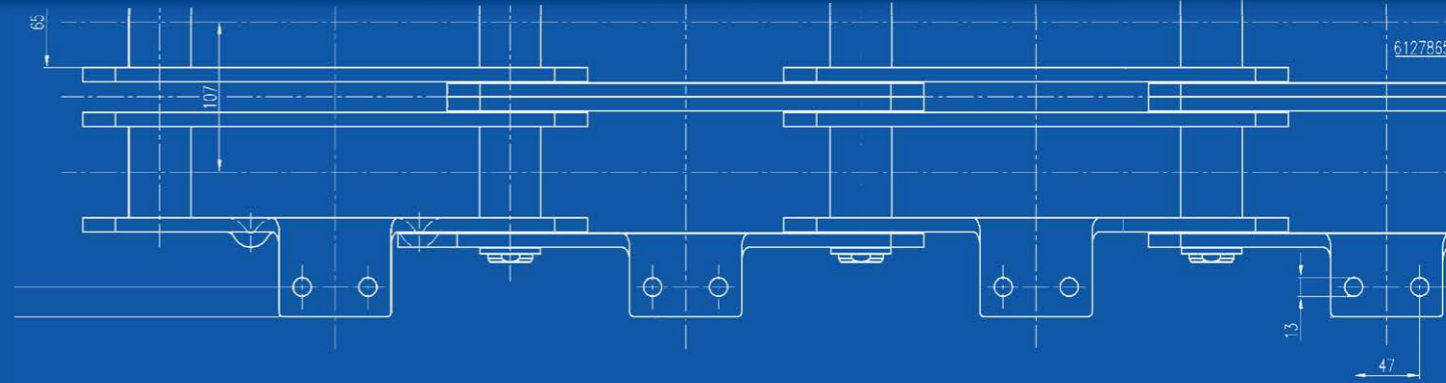
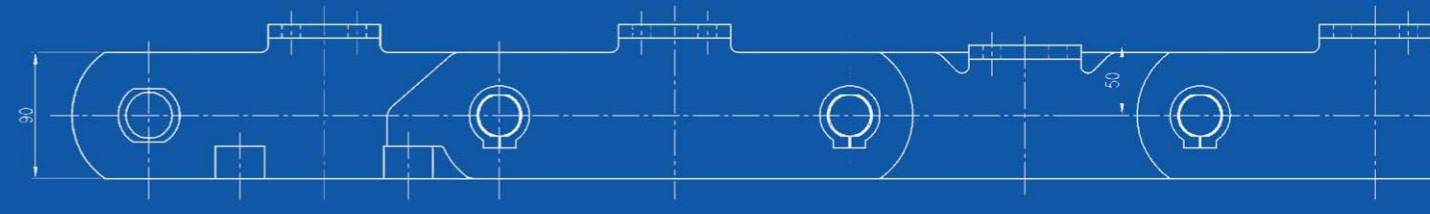
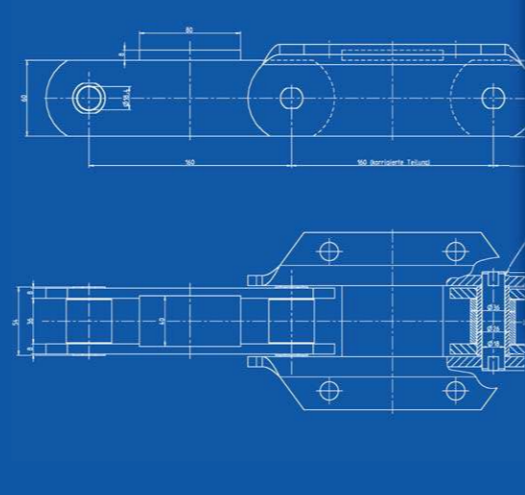
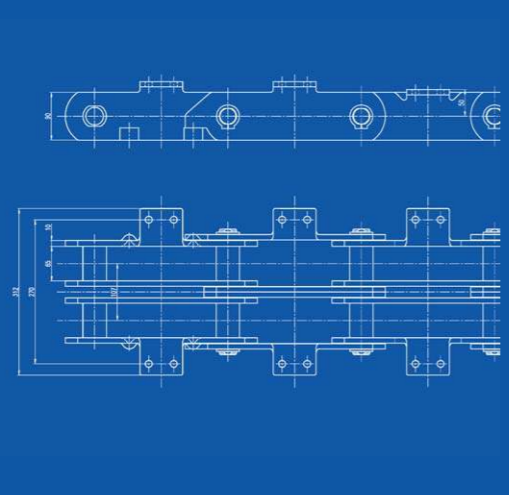
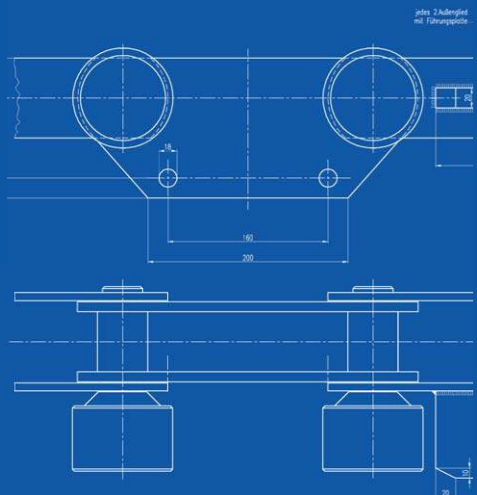

Altenilpe 16 • 57392 Schmallenberg
 TELEFON +49 (0) 2971 310 99 11
 FAX +49 (0) 2971 310 99 19
 E-MAIL uvalentin@auf.de
 INTERNET www.auf.de

Altenilpe 16 • 57392 Schmallenberg
 TELEFON +49 (0) 2971 310 99 10
 FAX +49 (0) 2971 310 99 19
 E-MAIL fgoeddecke@auf-export.de
 INTERNET www.auf-export.de



BULK MATERIALS INDUSTRY
 CHAINS • CHAINWHEELS • ATTACHMENTS

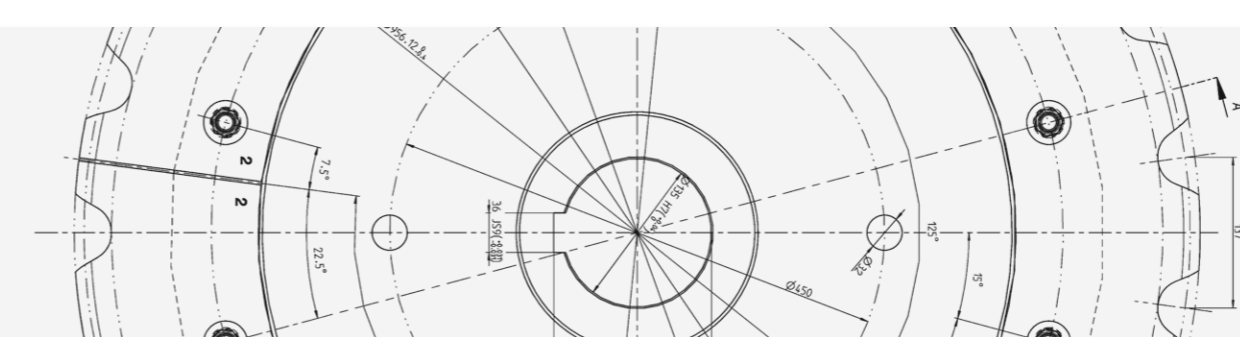
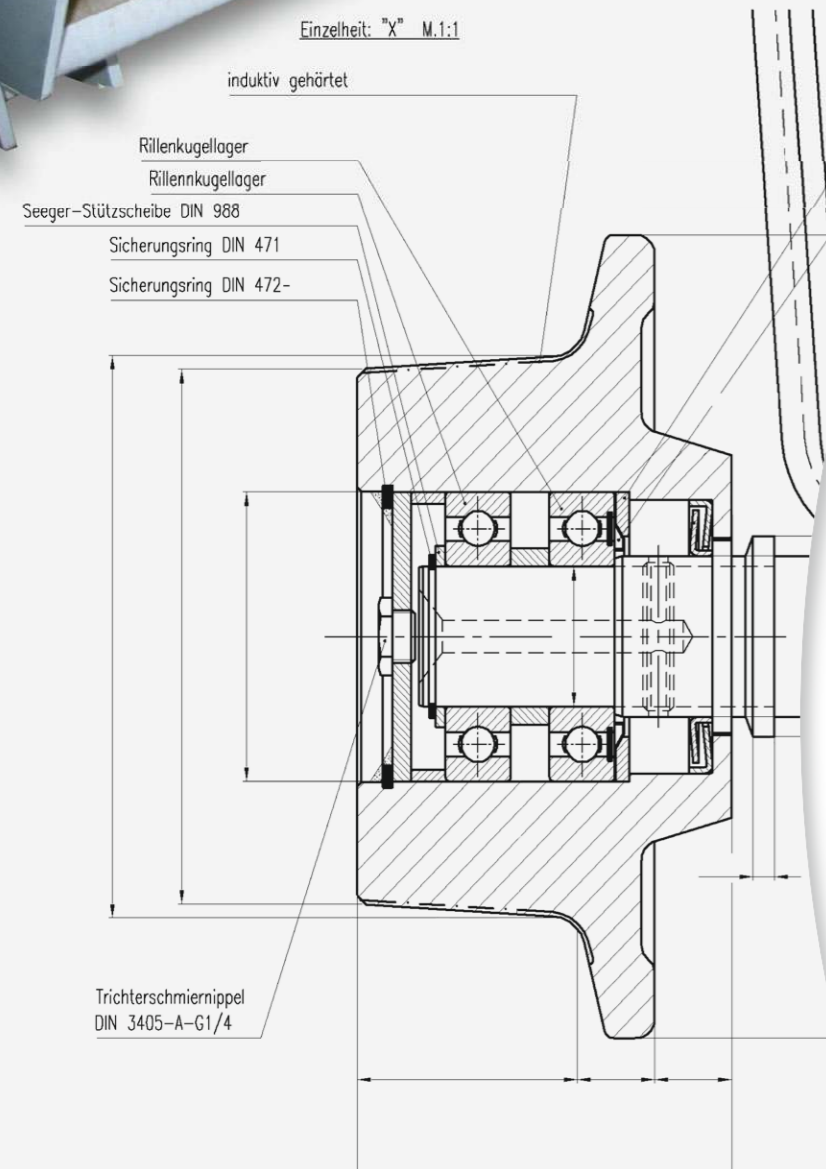
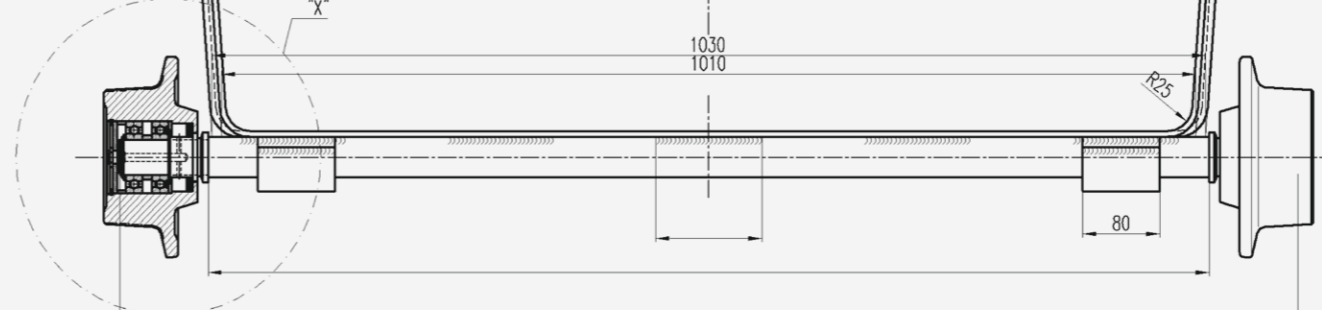

AUFT – QUALITY BASED ON KNOW-HOW

CHAINS • CHAINWHEELS • ATTACHMENTS

The companies AUFT and AUFT Export were founded on the 1st of January 2005.

We develop solutions in the fields of bushed conveyor chains, roller chains and special chains, as well as chain wheels and chain attachments.

Our knowledge and expertise speak for us, since our technically skilled employees have more than 20-years of experience in the chain manufacturing industry to ensure we supply high quality products supported by the best level of service.

Our products are in use in applications where it is necessary to transport or elevate products, people, bulk or general cargo efficiently and often under difficult conditions.

In the cement industry, such applications include bucket elevators and scraper chains, as well as conveyor belts including bucket cells and rollers.

Reap the benefits of our expertise. We survey your conveyor plants on site; specify materials with the appropriate heat treatment as well as the respective tolerances. We will optimize the products for your specific application.

Our product range includes chains with matching chain wheels or sprockets, complete conveyor systems with base plates and other attachments such as scrapers or carriers. Our products are used in inclined haulage installations, bucket wheel excavators, circular stacker reclaimers and bucket elevators of many well-known International original equipment manufacturers.

Our product range includes the following products:

- Bushed conveyor chains in accordance with DIN 8165 and DIN 8167
- Custom-made bushed conveyor chains
- Bushed conveyor chains in accordance with DIN 8164
- Galle chains in accordance with DIN 8150 and DIN 8151
- Custom-made draw bench and plate link chains
- Link-plate chains in accordance with DIN 8175 and DIN 8176
- Custom-made link-plate chains
- Roller chains in accordance with DIN 8187 and DIN 8188
- Special roller chains with attachments
- Fork link chains
- Custom-made disc band chains
- Block chains
- Additional custom-made special chains
- Chain wheels for every type of chain

Unsere Produkte finden zudem in anderen Branchen ihre Anwendung:

- Holzindustrie
- Stahlwasserbau
- Automobilindustrie
- Fahrtreppenindustrie
- Stahlindustrie
- andere Industriezweige